

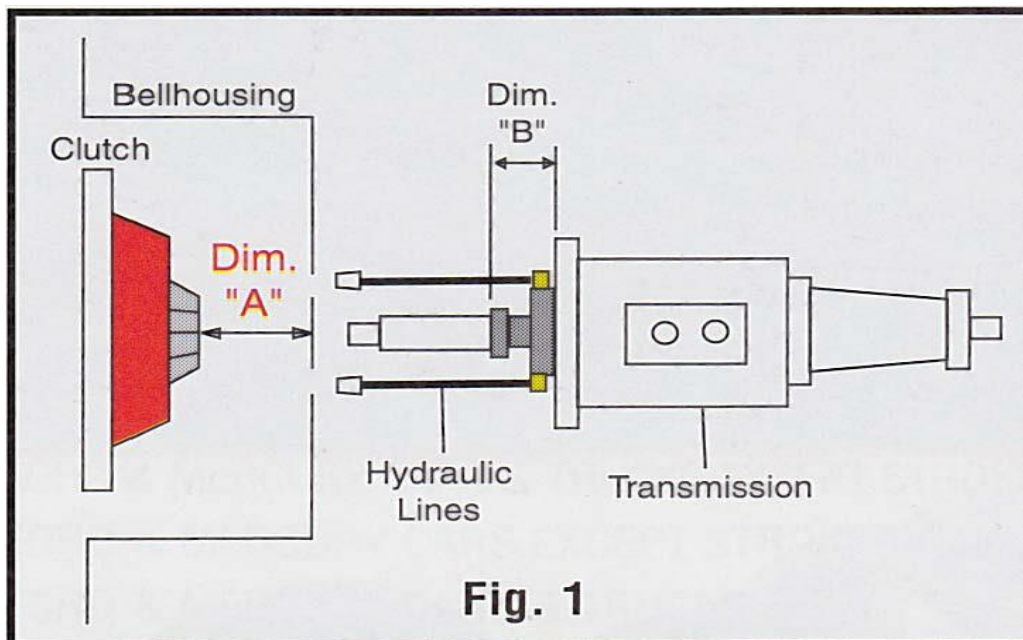

1300 Series Hydraulic Throw-Out Bearing Instructions

Congratulations! You have just purchased a precision engineered hydraulic throw out bearing assembly. Properly installed this bearing assembly will provide proper clutch engagement and release for many trouble free miles. Please review these instructions to become familiar with key parts along with the proper installation procedures for this product. Prior to beginning this installation let's be certain you have the correct hydraulic throw out bearing assembly for your application. McLeod offers two distinct types of hydraulic throw out bearing assemblies, the Slip-On style and the Bolt-On style. By taking a few easy measurements on your bell housing to clutch release fingers you can easily determine if this bearing is correct for your application.

McLeod Hydraulic Throw Out bearing assemblies will not work with counter weighted diaphragm style pressure plates (Centerforce). If the weights are removed the bearing will function as designed.



To Determine "Dimension A": With the bell housing, flywheel, disc and pressure plate bolted to the engine, measure the distance from the rear surface of the bell housing to the top of the release fingers on the pressure plate. If this dimension measures less than 3" you should use a "Bolt-On" style hydraulic throw out bearing assembly. If this dimension measures greater than 3" you should use a Slip-On style hydraulic throw out bearing assembly.

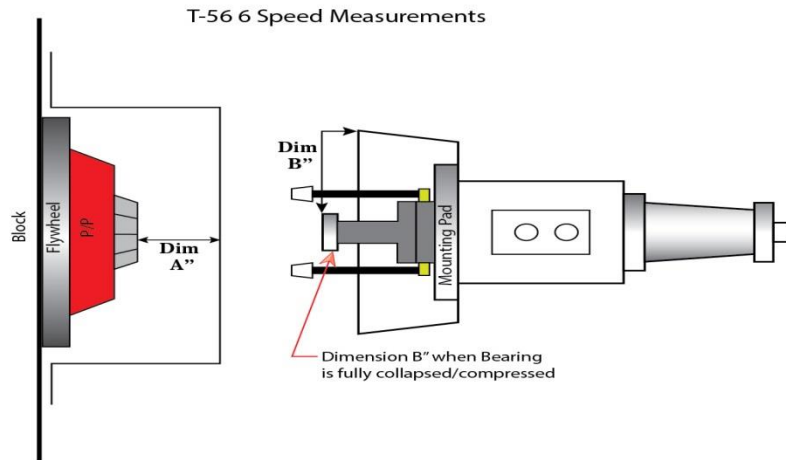

Note: T-56 transmissions have a recessed front intermediate plate. The 3" "A" dimension does not apply to these transmissions because of the recessed intermediate plate. Place a straight edge across the face of the throw out bearing surface when the bearing is fully compressed and measure to the flange of intermediate plate that touches the bellhousing. The bearing assembly on the T-56 is nested inside the front intermediate plate. This "B" dimension must be determined to be certain you have the correct style bearing assembly. When you have established both your "A" and "B" dimensions subtract "B" from "A" and your equation should be between .100" to .250" of clearance. If you can not achieve that acceptable clearance please call the McLeod Tech Line (714) 630-3668. For more info.

(Step 2). Before installing the hydraulic throw out Bearing Assembly let's take a look at your master cylinder and pedal assembly combination. Key parts to the system:

Master cylinder bore size ($3/4$ " recommended). Bore Diameter found on side of most aftermarket master cylinders.

- 1) Clutch pedal travel.
- 2) Master cylinder "Push Rod" stroke should be 1" minimum.
- 3) 6:1 Pedal ratio. See <http://www.mcleodracing.com/info/?id=5262> for more info.

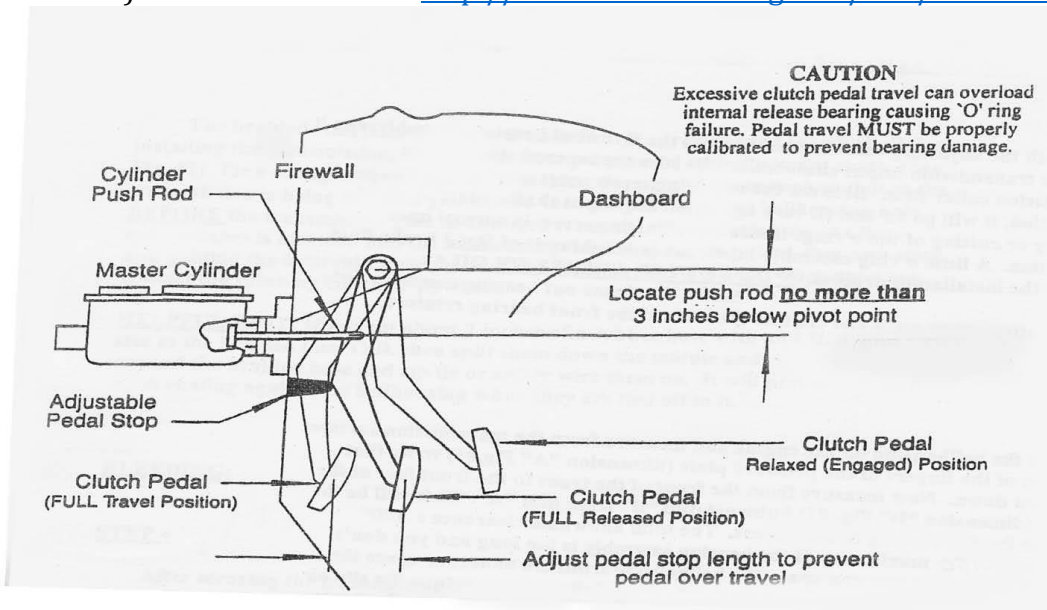

The master cylinder push rod needs a minimum of 1" of stroke if using a $3/4$ " bore master cylinder. Less travel is required with a larger diameter bore, although pedal effort will increase. More travel is required with a smaller diameter bore, with decrease in pedal effort. If a larger than $3/4$ " bore is required for your application, you can ease pedal effort by mounting the master cylinder and push rod higher up the pedal toward the pivot point. This will increase the amount of leverage you have with the pedal, thus an easier push. You will lose some push rod travel by doing this however with the larger bore master cylinder you are dispensing more fluid per stroke to compensate for the loss of pedal travel.

A 6 to 1 ratio is recommended with a $3/4$ " bore master cylinder. Example...If the center of the pedal pad is 12" from the pivot point, the push rod connecting point should be 2" below the pivot point. Quick math: Pedal pad is 12" below pivot point, divided by 6 (desired ratio) = 2". Push rod should be attached to the pedal assembly 2" from the pivot point.

The pedal should stop just prior to the piston, on the end of the cylinder push rod, contacting the front of the master cylinder.

This hydraulic bearing is designed with a constant running bearing that will touch the fingers of the clutch at all times, but does not apply pressure when the clutch is engaged. The assembly consists of four major parts: 1) Upper Housing, 2) Lower Housing, 3) Piston, 4) Constant running bearing. The unit does not need any tools to disassemble, unless you want to remove the AN-4 lines. See Fig A & B.

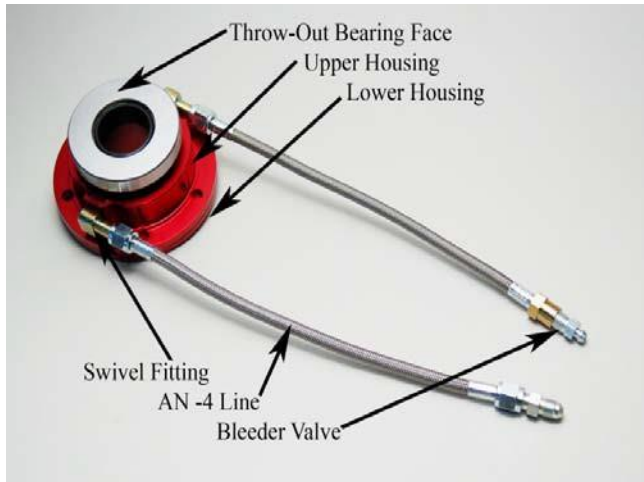

Figure A

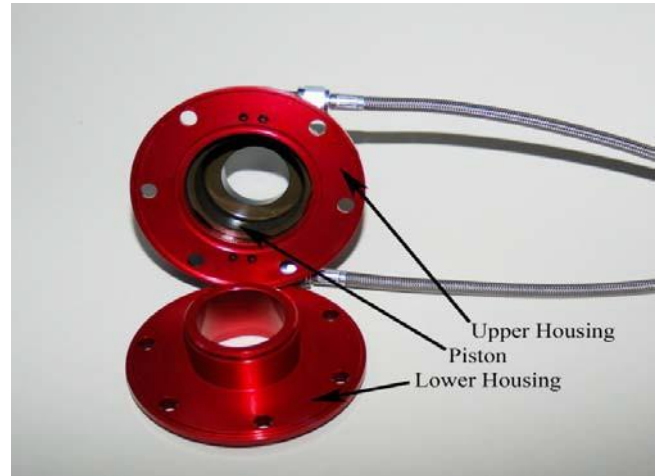

Figure B

Step 1) Be sure the throw-out bearing is in its full collapsed position. Place assembly on the bench with the bearing face up. Push down on the bearing face until it stops. Prior to installing the bearing assembly it is strongly recommended you fabricate a protective cover for the AN -4 lines where these lines exit the bell housing. The protective cover can be rubber hose, such as heater hose or similar material. This hose should be about 6" in length for each AN -4 line. Slice the rubber hose lengthwise and slip it over the AN -4 lines and secure with zip ties or safety wire. This will prevent the AN -4 lines from chafing on the bell housing and prematurely failing.

Remove the bearing retainer/input collar from the front of the transmission. For 1364 Bearing Assemblies: There is a factory bearing race between the input collar and the input shaft bearing assembly. **This race must be installed between the input shaft bearing and the McLeod bearing assembly!** Place the hydraulic bearing assembly over the input shaft and bolt it onto the front of the transmission. Allen head bolts about 1/4" longer than factory bolts work well. The relief at the rear of the lower housing must be aligned to the transmission similar to the stock relief position. **Note: A small bead of silicone will help seal the lower housing to the transmission. Remember the line with the bleeder valve must be at the top position!**

Muncie Transmissions: If your transmission has a slinger nut (found under the bearing collar) you must machine or grind the slinger flange off of the nut (approx .200") to clear the rear of the new bearing housing. The stock OD of the slinger nut measures 2.00", when machined the OD should measure 1.800". See Figure C & D

Caution – The slinger nut is a left hand thread. Remove by rotating clockwise. Reinstall slinger nut onto trans.



Figure C



Figure D

Step 2) With the bell housing, flywheel, disc and pressure plate bolted to the engine, measure the distance from the rear surface of the bell housing to the top of the release fingers on the pressure plate to determine Dimension "A". See Figure 1. Note that measurement here_____.

Measure from **the front mounting surface** of the transmission to the face of the throw-out bearing when compressed to determine Dimension "B". See figure 1. Note that measurement here_____.

Subtract dimension "B" from dimension "A". Note that number here_____.

You need a minimum .100" and a maximum of .250" for this assembly to function properly.
Add or remove shims to get within this range.

Example: Dimension "A" (2.600") minus dimension "B" (2.500") will equal .100" clearance. If you can not reach the required clearance with the standard supplied piston we do offer a taller piston (for additional cost) please call the McLeod Tech Line for details 714-630-3668.

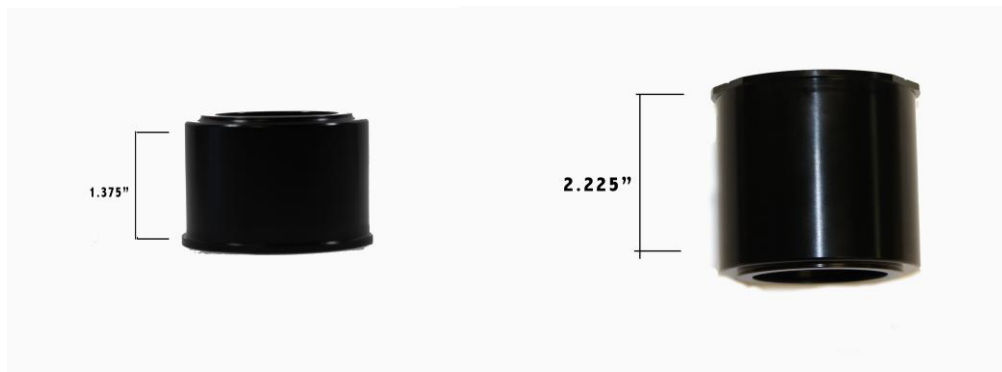

Comes standard with Bearing Assembly.

Optional 139079 piston.

STEP 3) The braided steel AN -4 lines on the hydraulic bearing are designed to swivel. Before installing the transmission, swivel both lines forward parallel with the input shaft. See Figure 1. Tie a heavy string around both lines, making the string long enough to feed the string through the opening in the bell housing where the lines will feed through (typically the fork hole) before the transmission is fully engaged into the bell housing. As the transmission is installed into the bell housing the string can be pulled simultaneously, thus swiveling and guiding the AN -4 lines out through the bell housing hole. The AN -4 lines must not contact the spinning clutch or flywheel when the engine is running. Be sure the protective hose on the lines are in the proper position to protect the AN -4 lines from chafing on the bell housing. **Always have the AN -4 line with the bleeder valve at the top when the bearing is properly installed. It is OK to swap the lines on the swivel fittings if necessary. Remember the line with the bleeder valve must be at the top position!**

Step 4) After securing the transmission and driveline; connect a line (not included with the bearing assembly) from the master cylinder to the input line (bottom line) of the hydraulic bearing using an AN -4 female flare. This bearing assembly is supplied with an A.N.-4 fitting screwed into the line. Fill the master cylinder with DOT 3 or DOT4 brake fluid. **DO NOT USE SILICONE BASED FLUID or DOT 5 FLUID!!** Use of **silicone** fluid will damage the O-rings resulting in leaks and or damage to the assembly. After the master cylinder is filled, bleed the bearing assembly. Example: Pump the pedal 3 to 4 times, with the bleeder valve open and the end of the opening submerged in a cup partially filled with brake fluid. This will release fluid and air trapped in the system. Continue the bleeding process until all of the air is removed from the system. Always keep fluid in the master cylinder while performing the bleeding process. Now reach into the cup and tighten the bleeder fitting. Set the cup aside and then be sure to tighten the bleeder valve. Once the bleeding is complete refill the master cylinder, just don't fill it all the way to the top. The fluid level should be ½" to ¾" from the top. This will allow room for the brake fluid in the reservoir when the bearing self adjusts. Unlike brakes, the fluid level will rise in the master cylinder, as the clutch wears, not lower.

Limited Warranty

McLeod Racing LLC, products are warranted to be free from defects in material and workmanship for the period of ninety (90) days, from the date of purchase. McLeod does not warrant or make any representations concerning its products when not installed and/or used strictly in accordance with the manufacturer's instructions for such; installation and operation, and in accordance with good installation and maintenance practices of the automotive industry. Products purchased used do not carry a warranty. This warranty is to the original purchaser and is non-transferable.

McLeod Racing LLC will not be held liable for the labor charges and other intangible or consequent losses that might be claimed as a result of the failure of any part, nor shall it be liable for damages or injury to persons or property resulting from the misuse or improper installation of any part subject to this warranty.

No merchandise may be returned for any reason unless prior return merchandise authorization number (RMA) has been obtained from McLeod. An RMA number may be obtained via www.mcleodracing.com or by calling McLeod directly.

McLeod Racing LLC reserves the right to examine all parts returned for warranty claim to determine whether or not any such part has failed because of a defect in material or workmanship. McLeod's obligation under this warranty shall be limited to repairing, replacing or crediting, at its option, any part found to be defective. All products returned to McLeod for warranty inspection must be prepaid by the customer under this warranty.

In a racing environment, the type of stress placed on automotive parts can vary dramatically by the type of use, driving style, track preparation, differing tire style and other variables that are out of McLeod's control. For this reason, any parts used in a racing environment shall be void of any warranty either expressed or implied.

There are no other warranties, either expressed or implied including, but not limited to, warranty of merchantability, and warranty of fitness for a particular purpose which extend beyond those set forth in the preceding paragraphs. This warranty shall be interpreted and applied in accordance with California law.

For any changes or updated versions of the warrant described above, please refer to www.mcleodracing.com before installation of product.